

Optional Information

Name of School:

Date of Inspection:

Vocational Program/Course/Room:

Signature of Inspector:

**Abrasive Wheel Machinery and Tools
Self-Inspection Checklist**

Guidelines: This checklist covers the regulations issued by the U.S. Department of Labor - OSHA under the General Industry standards 29 CFR 1910.215 & 1910.243 and the Construction standards 29 CFR 1926.303. All of these regulations were adopted by reference. It applies to fixed and portable abrasive wheel machinery. Natural sandstone wheels and metal, wooden, cloth, or paper discs, having a layer of abrasive on the surface are not covered by this checklist. This checklist must be used in conjunction with the checklist "Machines - General Requirements." Definitions are provided at the end of the checklist to help you understand some of the questions. Any question marked with the symbol (⊗) indicates a history of previous violations in vocational schools.

This checklist does not address extensive specifications for design of guards and flanges included in 29 CFR 1910.215. Consult the OSHA regulations for additional details.

General Requirements		<u>Please Circle</u>
1.	Do grinding wheels fit freely on the spindle? [29 CFR 1910.215(d)(2); 1910.243(c)(5)(ii) and 1926.303(c)(8)]	Y N N/A DK
2.	Is forcing the grinding wheel on the spindle prohibited? [29 CFR 1926.303(c)(8)]	Y N N/A DK

Comments/Corrective Action

Safe Schools: A Health and Safety Check

New Jersey Safe Schools Program/New Jersey Department of Education

3. ☹ Are all wheels closely inspected and sounded by the user (ring test) to make sure they have not been damaged in transit, storage, or otherwise before being mounted? [29 CFR 1910.215(d)(1); 1910.243(c)(5)(i) and 1926.303(c)(7)] Y N N/A DK
- Note: The spindle speed of the machine shall be checked before mounting of the wheel to be certain that it does not exceed the maximum operating speed marked on the wheel.
4. Is the spindle nut only tightened enough to hold the wheel in place? [29 CFR 1926.303(c)(8)] Y N N/A DK
5. Are all abrasive wheel operators required to use eye protection? [29 CFR 1926.303(c)(9)] Y N N/A DK
6. Are all grinding machines equipped with sufficient power to maintain the spindle speed at safe levels under all conditions of normal operation? [29 CFR 1926.303(a)] Y N N/A DK
7. Are all contact surfaces of the wheel, blotters and flanges flat and free of foreign material? [29 CFR 1910.215(d)(3) and 1920.243(c)(5)(iii)] Y N N/A DK
8. When a bushing is used in the wheel hole, is it positioned so as not to exceed the width of the wheel and not make contact with the flange? [29 CFR 1910.215(d)(4)] Y N N/A DK

Floor and Bench Grinding Machines

9. ☹ Are all floor and bench mounted abrasive wheels equipped with safety guards? [29 CFR 1910.215(a)(1) and 1926.303(a)] Y N N/A DK

Comments/Corrective Action

Safe Schools: A Health and Safety Check

New Jersey Safe Schools Program/New Jersey Department of Education

10. Does the safety guard cover the spindle end, nut, and flange projections? [29 CFR 1910.215(a)(2)] Y N N/A DK

11. Is the maximum angular exposure of the grinding wheel and sides not more than 90 degrees, except that when work requires contact with the wheel below the horizontal plane of the spindle, the angular exposure shall not exceed 125 degrees? [29 CFR 1910.215(b)(3) and 1926.303(c)(1)] Y N N/A DK

Note: In either case, the exposure shall begin at not more than 65 degrees above the horizontal plane of the spindle.

12. Are work rests provided which are rigidly supported and readily adjustable? [29 CFR 1910.215(a)(4) and 1926.303(c)(2)] Y N N/A DK

13. ⊕ Are work rests kept adjusted closely to the wheel with a maximum opening of 1/8 inch to prevent the work from being jammed between the wheel and the rest? [29 CFR 1910.215(a)(4) and 1926.303(c)(2)] Y N N/A DK

Portable and Other Abrasive Wheels

14. Are all machines with abrasive wheels greater than 2" in diameter provided with safety guards? [29 CFR 1910.243(c)(1)] Y N N/A DK

Note: Some abrasive wheels may be equipped with flanges depending on circumstances.

15. Is the maximum exposure angle on all grinding wheels 180 degrees or less? [29 CFR 1910.243(c)(3) & (4) and 1926.303(c)(5)] Y N N/A DK

Comments/Corrective Action

Safe Schools: A Health and Safety Check

New Jersey Safe Schools Program/New Jersey Department of Education

- | | | |
|-----|--|------------|
| 16. | When being used, is the guard on right angle head or vertical portable grinders located between the operator and the wheel?
[29 CFR 1910.243(c)(3)]1 | Y N N/A DK |
| 17. | Is the guard on right angle head or vertical portable grinders adjusted so that pieces of an accidentally broken wheel will be deflected away from the operator? [29 CFR 1910.243(c)(3)] | Y N N/A DK |
| 18. | Is the top half of the wheel on other grinders enclosed at all times? [29 CFR 1910.243(c)(4)] | Y N N/A DK |

General Requirements for Guards

- | | | |
|-----|--|------------|
| 19. | Is the guard and its fastenings of sufficient strength to retain fragments of the wheel in case of accidental breakage? [29 CFR 1926.303(c)(5)] | Y N N/A DK |
| 20. | Are guards mounted so as to maintain proper alignment with the wheel? [29 CFR 1910.243(c)(ii) and 1926.303(c)(5)] | Y N N/A DK |
| 21. | ⊗ Are tongue guards at the top of the wheel of bench, floor stand and cylindrical grinders adjusted to the decreasing diameter of the wheel so that there is never a gap of more than one-fourth (1/4) of an inch? [29 CFR 1910.215(b)(9)] | Y N N/A DK |

Note: Examples of cited violations include: there were no tongue guards on the grinders and the distance between the wheel and the tongue guard was approximately 1/2 inch.

Comments/Corrective Action

Safe Schools: A Health and Safety Check

New Jersey Safe Schools Program/New Jersey Department of Education

Definitions:

Ring Test means that the wheels should be tapped gently with a light nonmetallic implement, such as the handle of a screwdriver for light wheels, or a wooden mallet for heavier wheels. "Tap" wheels about 45° each side of the vertical centerline and about 1 or 2 inches from the periphery as indicated by the spots in the figures below. Then rotate the wheel 45° and repeat the test. A sound and undamaged wheel will give a clear metallic tone. If cracked, there will be a dead sound and not a clear "ring."

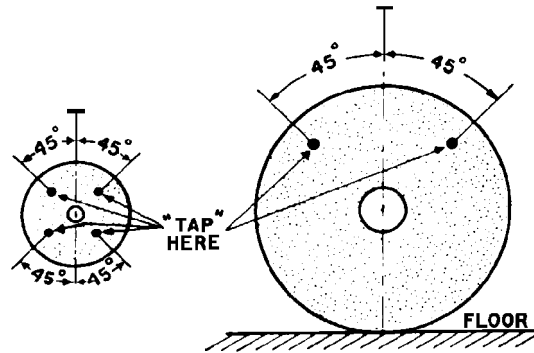

Light Wheels **Heavy Wheels**
Suspend from hole by Support on
clean hard floor small pin or
finger

Safe Schools: A Health and Safety Check

New Jersey Safe Schools Program/New Jersey Department of Education

This Page was Intentionally Left Blank.